

323197

© 1955 BY AMP INCORPORATED. ALL RIGHTS RESERVED. AMP PRODUCTS COVERED BY PATENTS AND/OR PATENTS PENDING.

REVISIONS			
SYM	DESCRIPTION	DATE	APPD
A	REDRAWN	5/27/65	FRW
B	REV. PER P-8347	6/10/77	REB.
C	REV G-4680	5-5-88	TMS/JT

METALLIC BAND:
STEEL QQ-S-698
(ASTM A109)

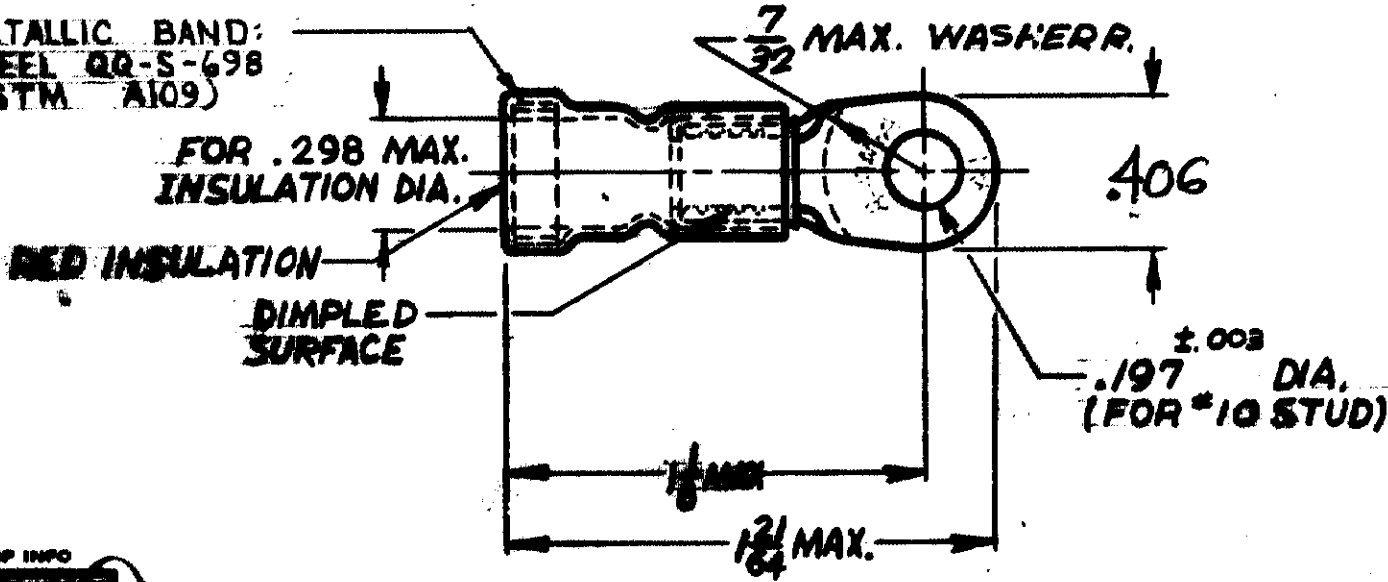

AMP INFO
LCC
6140

UNLESS OTHERWISE SPECIFIED		
DIMENSIONS ARE IN INCHES		
TOLERANCES ON		
FRACTIONS	DECIMALS	ANGLES
± 1/64	± .008	± 5°
MATERIAL COPPER (QQ-C-576)		
HEAT TREAT —		
FINISH TIN PLATED (MIL-T-10727) TYPE I		

TONGUE MATERIAL THICKNESS .040

SIGNATURE	DATE
DR. <i>L.E. Conley</i>	5/27/65
CHK. <i>R. Wolfe</i>	7/0/65
APPD. <i>J. Hill</i>	5/27/65

AMP AMP INCORPORATED
HARRISBURG, PENNSYLVANIA

NAME
**WIRE TERMINAL
AMPLI-BOND
RING TONGUE
WIRE SIZE : 8**

DSGN APPD	CODE IDENT NO	SIZE	NUMBER
	00779	A	323197
OTHER APPD	SCALE	WT	CALC
	2:1		

CUSTOMER DRAWING OF 1